



COVE TRAPEZOID COLLECTION



CV-2424

CV-30(xx)
Weight: 305 lbs
BTUs: 55,000 LP/NG

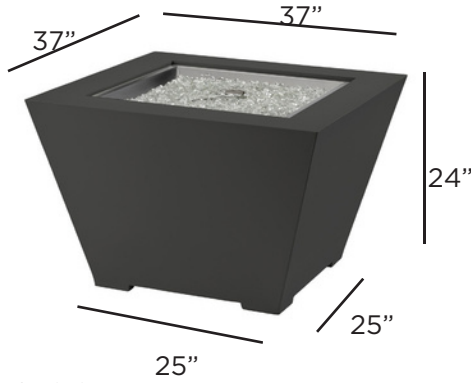

CV-2424MM



CV-2424WT



CV-2424LN



CV-2424



CV-2424ES



Midnight Mist
MM



White
WT



Earthstone
ES



Natural Grey
NG



Latte
LT



Linen
LN

FEATURES

- UL tested and ULC listed for safety
- Advanced Crystal Fire Plus® Burner technology
- Prepared for use with liquid propane; includes natural gas conversion kit
- Automatic gas shutoff
- Timers and E-stops for commercial use
- All essential components included in one SKU (fire media, burner cover, and ignition)

BENEFITS

- Supercast™ concrete base is a glass fiber reinforced concrete (GFRC), providing exceptional strength and durability compared to traditional concrete
- Can be spec'd in at the start of outdoor room designs
- Grey glass burner cover can convert fire pit into a table when not burning



COVE TRAPEZOID COLLECTION

FIRE MEDIA

Bags Required: *Glass Gems(4), Tumbled LavaRock (3), Black Lava Rock (1.5)*



CFG-A (5 lb bag)
Amber

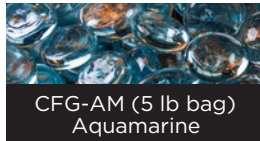

CFG-AM (5 lb bag)
Aquamarine

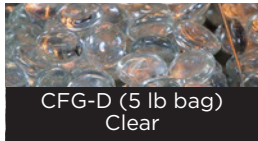

CFG-D (5 lb bag)
Clear



CFG-O (5 lb bag)
Onyx

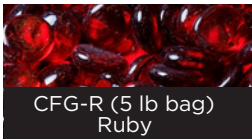

CFG-R (5 lb bag)
Ruby



LAV-TMB (6 lb bag)
Tumbled Lava Rock



LAVA-BLK (15 lb bag)
Black Lava Rock



CF20-LOGSET
Ceramic Log Set

ACCESSORIES

Protective Covers



CVR3939

Burner Covers



2424GGC

Glass Wind Guards



GG-2424

IGNITION OPTIONS

Manual

Mounted on firepit only

Standard
Control Panel



VCSV-CP-BLK

Electronic

Can be mounted on or away from firepit

4-Hour Timer



4HRTC

On/Off Switch



DSI-CP-BLK

Emergency Stop



CFP-ESO-CP

On/Off Switch with
Emergency Stop



WES-CP

4-hour Timer with
Emergency Stop



4HRTES-CP