



THE OUTDOOR  
GREATROOM  
COMPANY

# The Cove Fire Pit

Installation Instructions for CV-54 and CV-72



## IMPORTANT

Please consult your Crystal Fire instruction manual for detailed instructions and important information related to the burner installation including: lighting and operating instructions, safety information, and proper tightening of connections with two wrenches.

**DO NOT ATTEMPT TO INSTALL CRYSTAL FIRE BURNER WITHOUT FIRST CONSULTING THE CRYSTAL FIRE OWNER'S MANUAL.**

### Contents

Required Tools.....	2
Included with your Fire Pit.....	3
Assembly Instructions.....	4
Sparker Box Installation.....	4
Gas Connections.....	5
Burner installation .....	6
Fire Glass Installation.....	7
Frequently Asked Questions.....	8

### Required Tools

**FOUR people are required for this installation.**



- 2 Open Ended Wrenches  
To secure gas connections.



- Leather Gloves  
To protect hands from rough edges found on fire pit during installation.



- One AAA Battery (not included)  
Required for electric spark igniter installation.



- Utility Knife  
To cut and remove packaging.



- Power Drill  
To remove support board from crate.

# Included With Your Fire Pit

**CV-54 / CV-72**

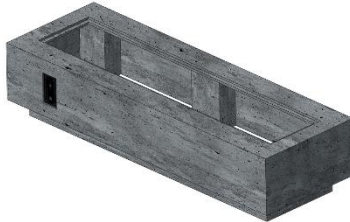

**CV-54/CV-72 Base and Pedestal  
with Control Panel**

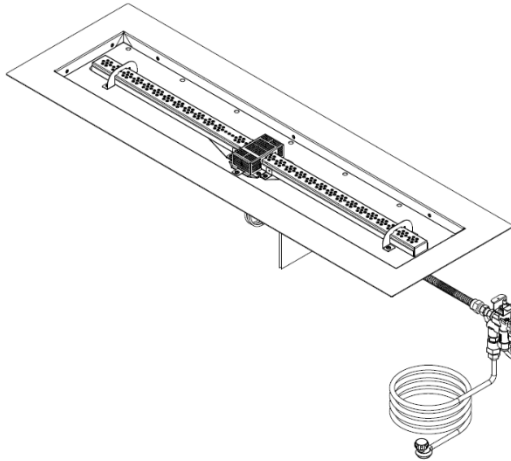

**Burner Assembly  
(P/N: BP1242-CV-B, BP1264-CV-B,  
BP1242CVDSIXX-B, BP1264CVDSIXX-B)**

**Fire Glass Beads  
(4 bags CFG-D for CV-54, 5 bags CFG-D for CV-72)**

# Assembly Instructions

## 1. Remove Cove Fire Pit Base from Packaging crate

- Four People are required to lift base out of packaging and place into final location.



## 2. Sparker Box Installation

- Remove sparker cap and hex nut. Insert AAA battery (not included) with + end out.
- Install sparker into control panel as shown below, secure using hex nut and replace sparker cap.
- Depress sparker button to ensure your sparker is working properly. You should hear the spark behind the sparker box.

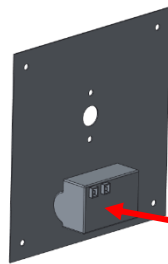
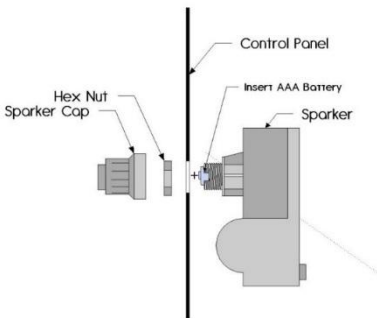

Locate and orient sparker box on control panel as shown. Sparker box must be installed **before** burner valve.

### 3. Gas Connections

**Read and understand your Crystal Fire Burner Owner's manual before beginning burner hookups or using the device. Do not use Teflon tape or pipe dope on flare fittings.**

- See Crystal Fire® Plus instructions for burner installation.
  - All gas connections were completed at the factory.
- Check all connections for leaks. If needed, tighten connection with 2 wrenches and re-check for leaks.
- Attach burner valve to control panel with provided screws as shown below. Ensure spark box is installed before this step.

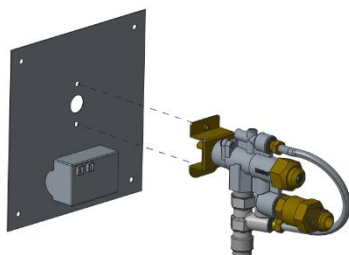

### 4. Thermocouple Installation

- Refer to Crystal Fire® Plus instruction manual for detailed attachment of thermocouple.
- Attach thermocouple to burner valve as shown below.

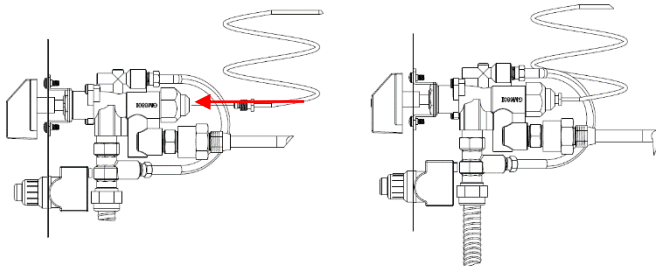

5. **Connect Ground wire and Electrode wire from burner to sparker box.**

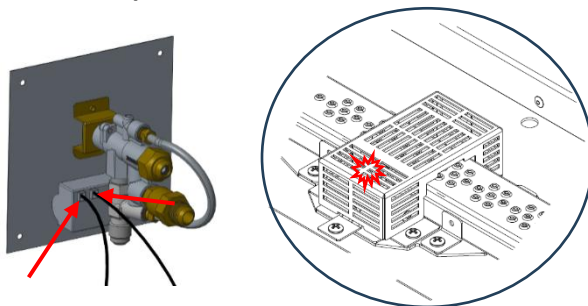

- Connect ignitor and ground wire to sparker box. Both wires can connect to either connection point. The unit will operate in either configuration.
- Test system by pushing the button on the igniter. Consult the troubleshooting section of the Crystal Fire® Plus Burner Owner's Manual, if the spark is weak, intermittent, or not present.

6. **Drop burner into base.**

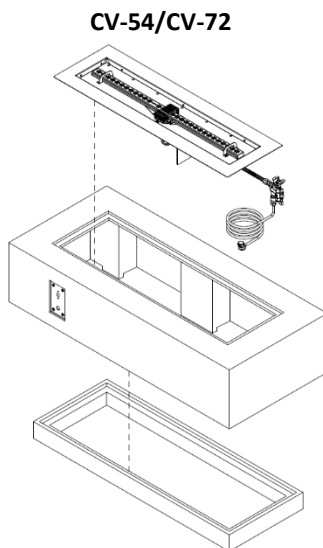

- Place Pedestal down first, followed by the base.
- Place burner assembly into recessed opening in base.

## 7. Install Fire Media

- Scatter all included glass beads, lava rock, or other approved fire media evenly across entire burner surface.

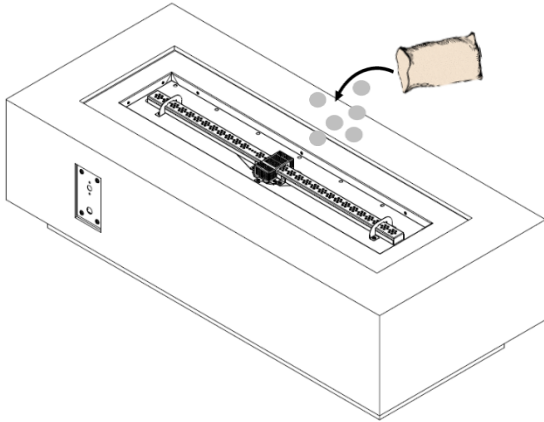

**DO NOT OPERATE CRYSTAL FIRE® PLUS BURNER  
WITHOUT INCLUDED GLASS BEADS OR OTHER  
APPROVED FIRE MEDIA**

### **IMPORTANT**

Please consult your Crystal Fire® Plus instruction manual for detailed instructions and important information related to the burner installation including: lighting and operating instructions, safety information, and proper tightening of connections with two wrenches.

**DO NOT ATTEMPT TO INSTALL CRYSTAL FIRE® PLUS BURNERS  
WITHOUT FIRST CONSULTING THE CRYSTAL FIRE® PLUS OWNER'S  
MANUAL.**

### **WARNING**

After consulting the manual and following instructions, remember; before operating, all gas connections must be fully checked for leaks

# Frequently Asked Questions

## *What is Supercast?*

Supercast is a proprietary blend of fiber glass and polymer fortified concrete. This guide will help inform you about some unique characteristics of a Glass-Fiber reinforced concrete top and help you keep it looking like new for years to come.

### ***Supercast Glass Fiber Reinforced Concrete (GFRC) Products Warranty Information.***

- One year warranty on structure and finish. Cracks that exceed 1/8" displacement in either height or gap and determined to be a product of either material or workmanship, shall be warrantied for a period of 1 year. Non-structural hairline cracks are possible and shall not be considered a manufacturing defect.
- Natural variations in color, shade, porosity, pitting and texture may occur with GFRC products and are considered inherent and valued qualities of the material. Variation in shape and dimension can be up to  $\pm 1/4"$ .
- Under most conditions, re-sealing is suggested every 1-2 years using a clear matte finish solvent based concrete sealer. The frequency is dependent on ambient conditions including, but not limited to: frequency of use, exposure to UV, saltwater, chlorine, hard water, air temperature, and humidity.
- If covering a GFRC item, use a one-way breathable cover as supplied by The Outdoor GreatRoom Company, LLC (OGC) or equivalent. Do not use other materials or objects to hold down or secure a protective cover on top or around the GFRC item.
- While maintaining a regular re-sealing maintenance schedule in combination with using a one-way breathable cover, the color of a GFRC item will fade minimally over time and should not require re-staining or re-coloring. If re-staining, contact OGC for an approved stain type and color.
- When used in conjunction with a Crystal Fire Plus burner setup, all custom GFRC products are required to operate with an OGC glass guard installed around the burner. The glass guard improves the flame appearance and reduces the risk of unnecessary thermal stress on the GFRC surface. A glass guard is recommended for stock GFRC products.

### ***What makes a concrete fire pit unique?***

Your fire pit is handcrafted from Portland cement concrete and reinforced with glass fibers to provide exceptional strength and durability compared to traditional concrete. Supercast is typically 1/3 of the thickness of traditional concrete with 3 times the strength. Each piece offers its own uniqueness; you may notice color variations in your fire pit. This is intentionally done during the molding process to create a unique natural appearance which mimics natural stone.

### ***Maintenance Instructions:***

To keep your fire pit looking new, we recommend the following:

- Keep covered when not in use to protect from buildup of water, snow, dust, dirt, and debris and direct sunlight whenever possible.
- Do not put the cover on when the table is wet.
- If any colored liquids such as wine or soda are spilled on your top, clean off immediately to avoid possible staining.

- We recommend cleaning your top regularly with a mild mixture of dish detergent and warm water; rinse thoroughly.  
*How do I reseal Supercast surfaces?*
- First clean using a diluted solution of vinegar and water to remove any dirt or debris that may have accumulated on the surface and allow to dry.
- Reseal the surfaces using the stain/sealers below based on the color fire pit you have. Apply the stain/sealer using a foam roller and allow it to cure for 24 hours before exposing to water or use. The stain/sealers can be purchased at any Sherwin-Williams store.
- Minor surface scratches can be removed by using the stain/sealing method above. Clean the area affected and apply the stain/sealer.
- Natural Grey - MN Concrete Custom Grey: H&C Exterior Color Top solvent-based solid color sealer, Tint Base-Deep, satin sheen. The color mix is for 5 gallons, vendor can adjust color amounts based on size being purchased:

BAC Colorant	OZ	32	64	128
W1-White	4	42	-	-
B1-Black	4	47	-	-
R2-Maroon	-	15	-	-
Y3-Deep Gold	2	51	-	-

- White - MCP White: H&C Exterior Color Top solvent based solid color sealer, Tint Base-White, satin sheen. The 1 gallon color mix is:

BAC Colorant	OZ	32	64	128
B1-Black	-	2	1	-
Y3-Deep Gold	-	2	1	-

- Midnight Mist - MCP Raven: H&C Heavy Shield water based solid color enamel/stain, Tint Base-Ultradeep, semi-gloss. The 1 gallon color mix is:

BAC Colorant	OZ	32	64	128
W1-White	-	31	1	1
B1-Black	6	21	-	-
R2-Maroon	-	13	-	1
Y3-Deep Gold	-	30	-	-



WARNING: This product can expose you to chemicals including Carbon Monoxide and Benzene which are known to the State of California to cause cancer or birth defects or reproductive harm. For more information, visit [www.P65Warnings.ca.gov](http://www.P65Warnings.ca.gov)

Thank you for purchasing an Outdoor  
GreatRoom Company product!



**Warranty:** Fire pit tables are covered under a 1- year  
manufacturer's warranty. Please visit  
[https://outdoorrooms.com/pages/product-  
support\\_\\_product-registration](https://outdoorrooms.com/pages/product-support__product-registration)  
to register your product.



9583 217<sup>th</sup> St. W. • Lakeville, MN 55044  
Toll Free: 1-866-303-4028 • [Sales@OutdoorRooms.com](mailto:Sales@OutdoorRooms.com)