

Isokern Magnum 72" Fireplace



Project Name: _____ Location: _____

Address: _____ Gate Code: _____

Project Manager: _____ Contact #: _____

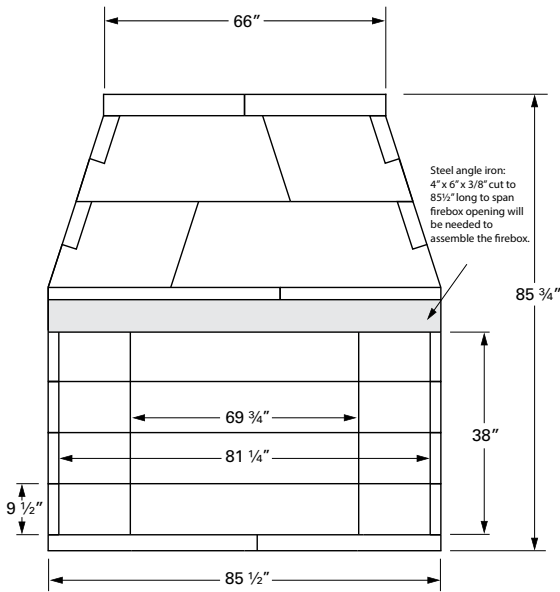

Front View

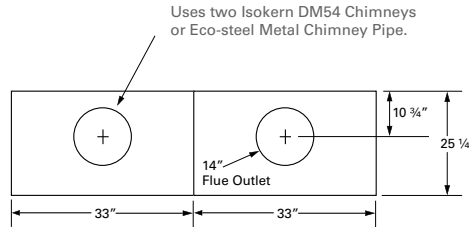

Top View

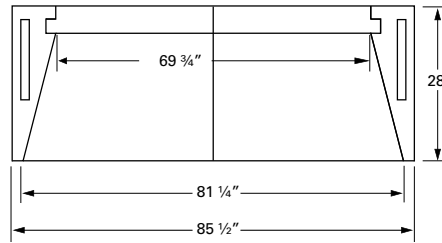

Plan View

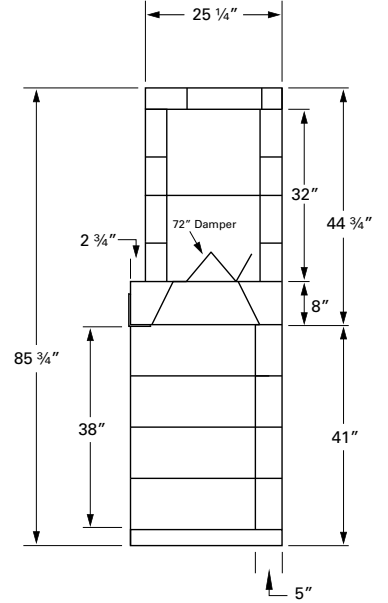

Side View

FIREPLACE OPTIONS

- Hearth Height: _____
- Brick Type: _____
- Brick Color: _____
- Brick Pattern: _____
- Damper: _____
- Chimney Type: _____
- Offset: _____
- Other Options: _____
- Spark Arrestor/Termination: _____
- Energex RSHT Chimney Fan: _____
- Decorative Termination: _____
- Gas Log Set: _____
- Wood Grate: _____

Notes: _____

MINIMUM FRAMING DIMENSIONS

Framing dimensions maintain 1 1/2" clearance to combustibles. Refer to product manual for further installation instructions.

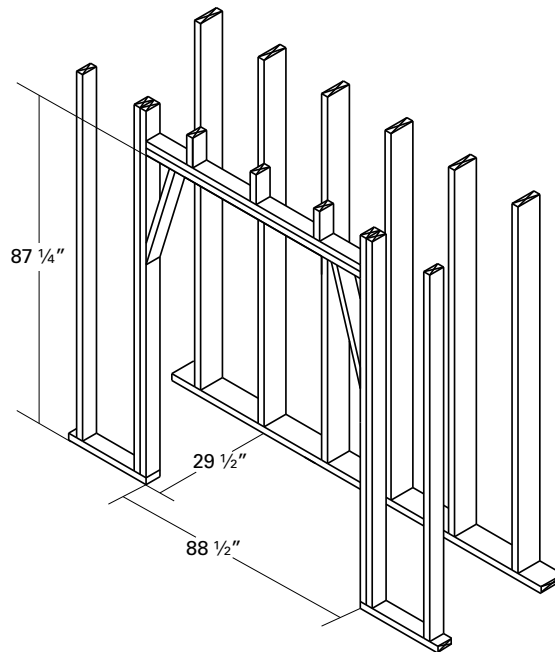

The total weight for the Magnum 72" fireplace is approximately 2952 lbs. This dry weight includes fireplace pumice components only, additional weight from mortar, damper, firebrick and chimney not included.